

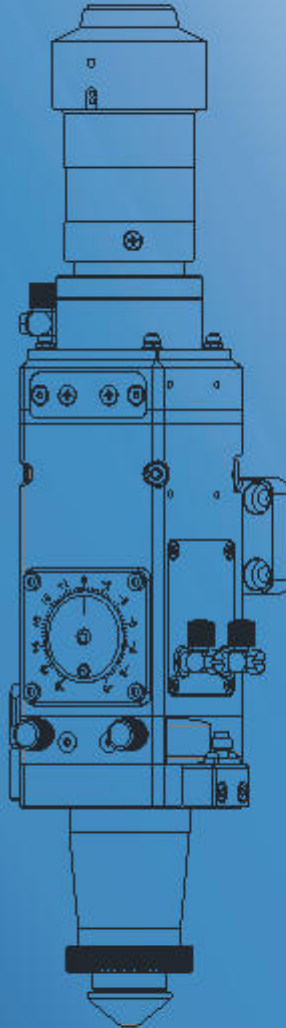

# Laser Cutting Head MN15A



User Manual

Shenzhen Worthing Technology Co., Ltd.

Please read this manual carefully and make sure you understand its contents before using the laser head. Please keep this manual for future operation and maintenance.

---



请勿直视激光！  
 请使用符合 DIN EN  
 207 和 标准  
 的 护目镜！



运动时请不要将身  
 体任何部分与激光  
 头接触！



切割后有余温可能  
 会烫伤！



激光头为精密产品  
 请勿撞击！

# Contents

1、	Cover	
2、	Product Structure	-----1 ~ 2
	2.1 Dimension	----- 3
	2.2 Debug	----- 4
	2.3 Fiber Connection	-----5 ~ 6
	2.4 Centering Adjustment	----- 7
	2.5 Focusing Adjustment	----- 8
3、	Maintenance	
	3.1 Maintenance	----- 9
	3.2 Ceramic/nozzle	----- 10
	3.3 Protection lens 1	----- 11
	3.4 Protection lens 2	----- 12
	3.5 Troubleshooting	----- 13
	3.6 Consumables	----- 14

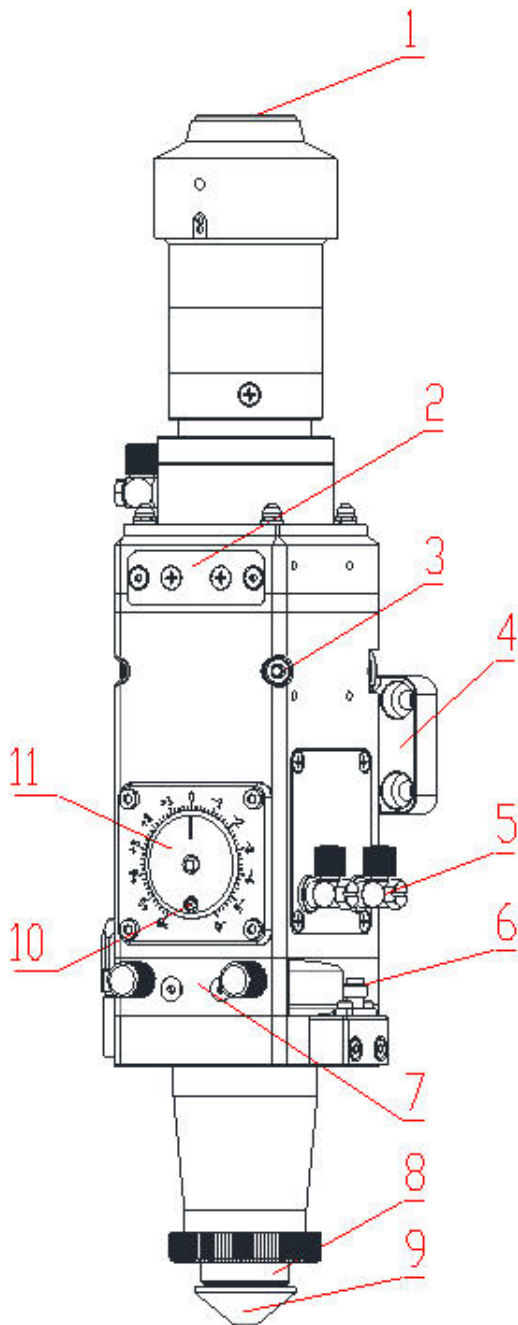

- 1.Fiber connector
- 2.Collimation protection lens
- 3.Center adjust
- 4.Mounting plate
- 5.Water connector
- 6.Height control signal interface
- 7.Protection lens
- 8.Ceramic ring
- 9.Nozzle
- 10.Focusing lock
- 11.Focusing dial
- 12.Gas connector

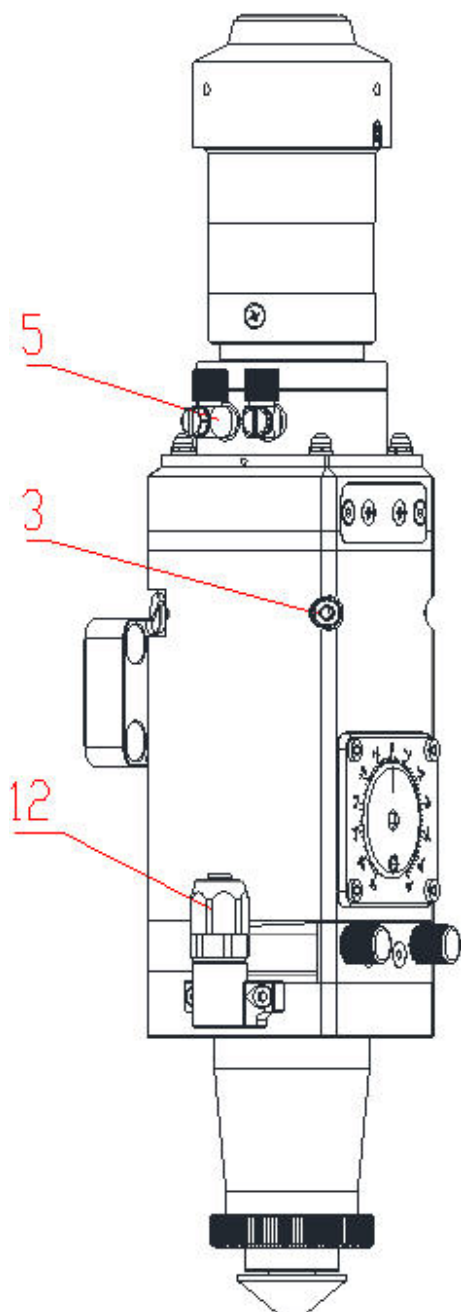

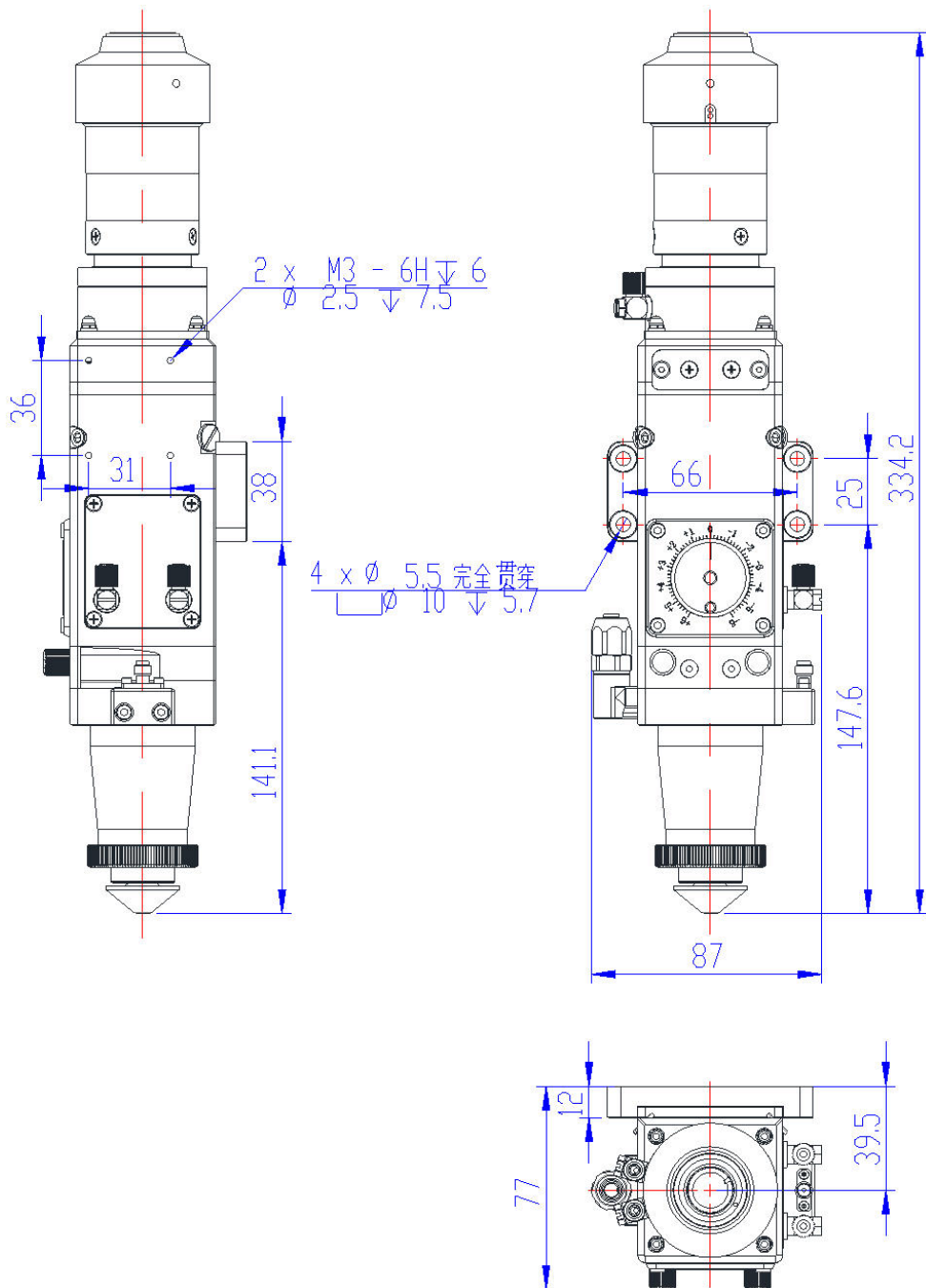

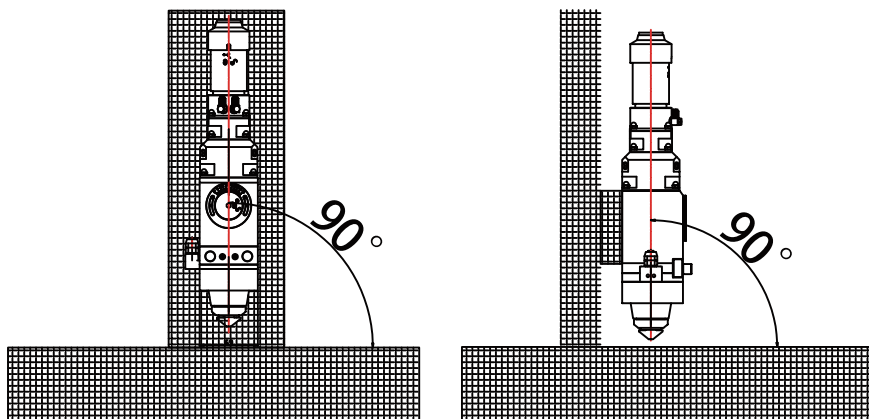

Step 1: set the laser power to 500W, make a short burst at the height of 5cm from the plate to burn a round scorch on the plate;

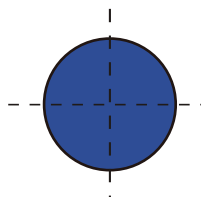

Step 2: set the laser power to 100W, make a short burst at the height of 1~5 cm from the plate to burn a round scorched spot on the plate;



Step 3: compare the concentricity.

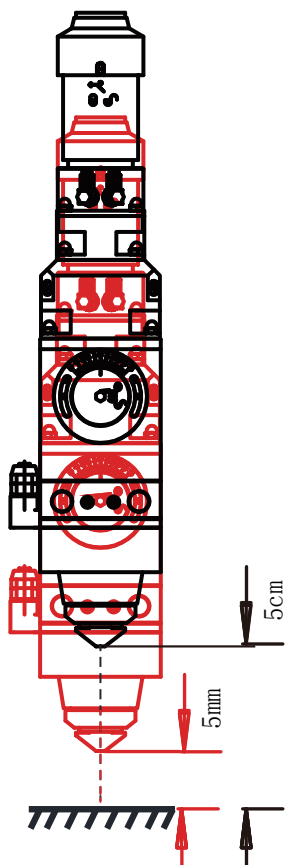
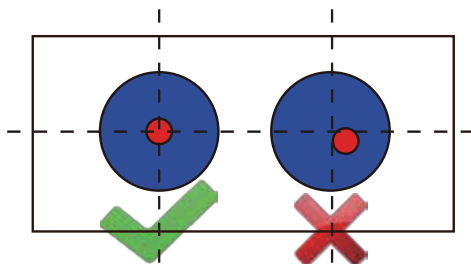



1. Place the laser head and optical fiber connector in a horizontal state;
2. Clean the QBH and fiber with clean rods and anhydrous ethanol.

Before installation, please lock the protective cap on the top of the fiber optic rod tightly to avoid loosening during the working process and generating optical path deviation which may effect the cutting or even burn the fiber optic rod and cutting head.

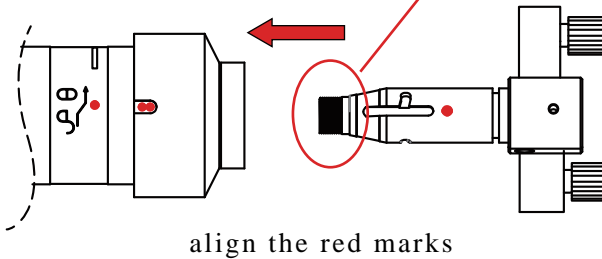

3. Insert the fiber connector into QBH gently;

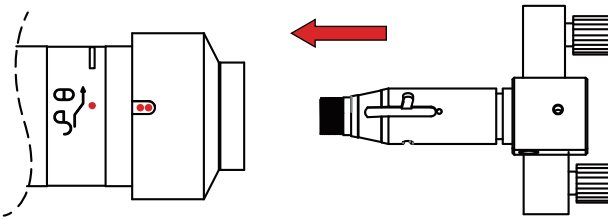

4. After inserting, turn the turning rim in the direction as Picture 8 until the two red marks are aligned to the white mark.

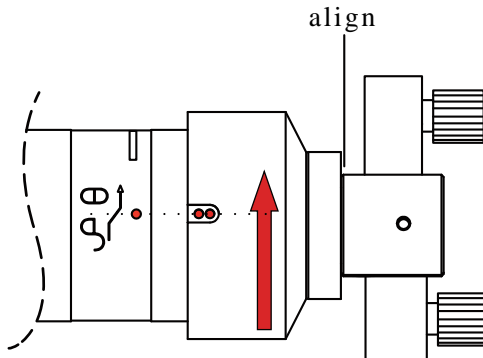

5. Then pull the turning rim as below

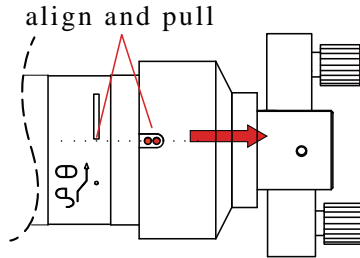

6. Turn the rim in the direction as below at moderate intensity to make it tight.

The red marks can be aligned to or over the middle of the white bar, but do not twist any more when it is in the right position.

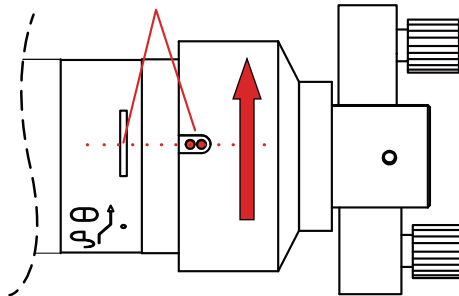

Be careful not to twist it vigorously to avoid damaging the precision structure.

To avoid dust getting into the fiber optic interface, clean the fiber optic rod first and insert it with the laser head in a horizontal position.

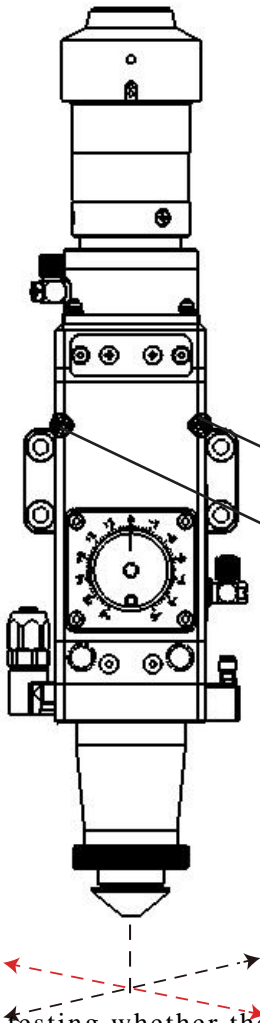

1. Y horizontal adjustment screw
2. X horizontal adjustment screw

1. Adjust the X/Y screw by allen wrench and make the beam pass through the center of nozzle;  
 2. The cutting effect is perfect when the beam pass through the center of nozzle;  
 3. If the beam does not pass through the center of nozzle, it may cause the beam could not be emitted out or bad cutting effect and so on.

2  
1

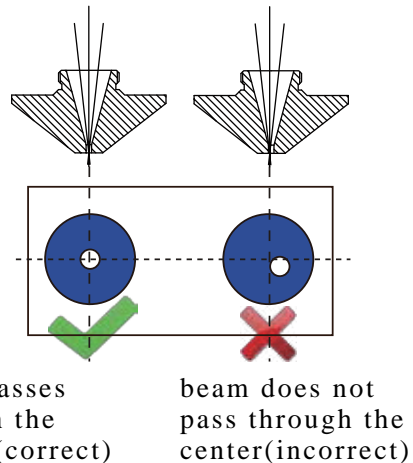

beam passes through the center (correct)

beam does not pass through the center (incorrect)

Methods of testing whether the beam pass through the center of nozzle:

1. Paste the transparent tape on the outlet of the nozzle (prefer to a new or undeformed nozzle);
2. Set the power of laser machine to 50W (take 500W for example, adjust the short burst power for 10%);
3. Take off the transparent tape after the beam has been emitted for 1 – 2 seconds;
4. Face the tape to light source and observe the round mark of nozzle on the tape and burning spot of laser passing through the tape;
5. If they are concentric, the testing result is good, but if not, please keep adjusting.

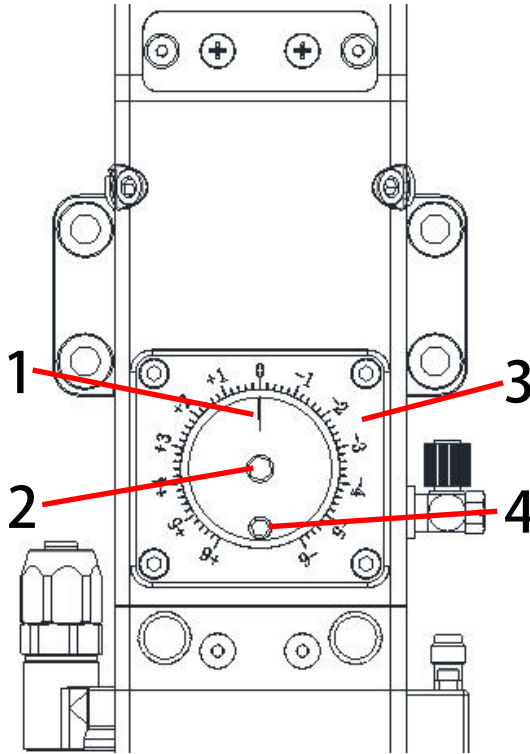

- |                 |                                   |
|-----------------|-----------------------------------|
| 1 Focus Pointer | 2 Focus Adjustment Hexagonal hole |
| 3 Focus Dial    | 4 Focus Locking Device            |

1. Focus pointer scale points in the positive direction, focus moves up (inside the nozzle ); points in the negative direction, focus moves down (outside the nozzle)
2. Insert a hexagonal spanner into the 2 focus adjustment hexagonal hole and turn it clockwise or counterclockwise so that the focus pointer 1 points to the appropriate scale
3. The focus adjustment dial allows user to view the set amount of focus out of focus
4. Focus lock, before processing or out-of-focus reset, be sure to lock the focus lock to a void focus changes during processing; factory default is not locked, before the first time using it, please check the lock!



check



distance



replace

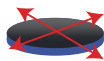

adjust the lens



clean



maintenance interval



calibration

**Tip:**

Before maintenance, please use compressed air to blow the dust on the surface of the cutting head, and then use a clean rag with alcohol to clean the corresponding parts.

**Tip:**

After each maintenance of the ceramic ring and nozzle, it is necessary to re-calibrate.

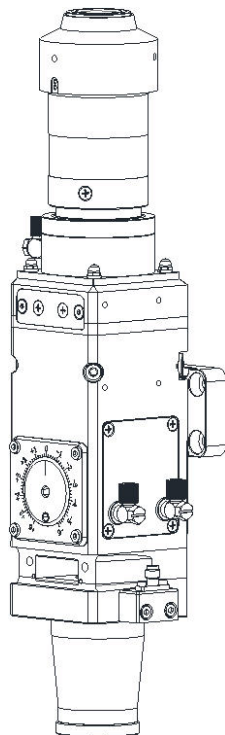

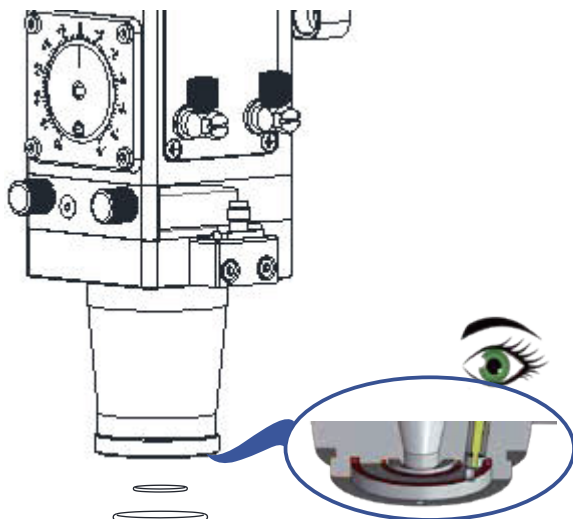

power



cooling gas



cutting gas

Tip:

Before maintenance, please use compressed air to blow the dust on the surface of the cutting head, and then use a clean rag with alcohol to clean the corresponding parts.

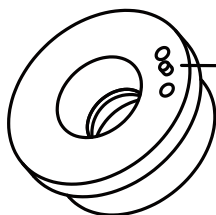

dowel

Tip:  
After each maintenance of the ceramic ring and nozzle is completed, it is necessary to recalibrate. And test whether the light is in the centre.

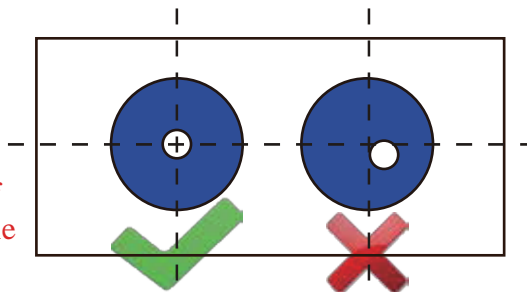

centering test

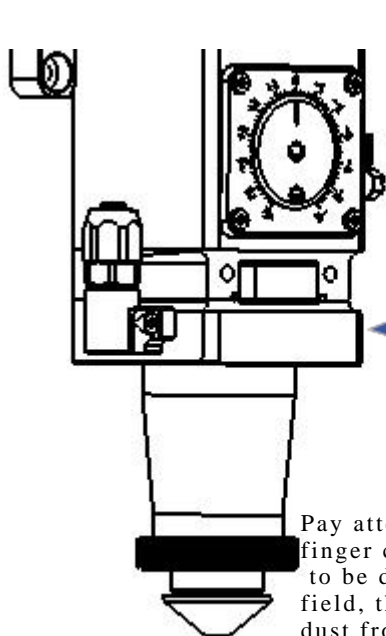

**Tip:**  
Before maintenance, please use compressed air to blow the dust on the surface of the cutting head, and then use a clean rag with alcohol to clean the corresponding parts.



power



cooling gas



cutting gas



Pull out horizontally after loosening the screws

Pay attention to dust prevention: wear dustproof gloves and finger cots when removing and installing lenses, which needs to be done in a clean place. (When replacing lenses in the field, the window can be sealed with masking tape to prevent dust from entering the interior and causing contamination.)

Before clean or change the lens, record the position and direction of the lens; and after the maintenance, just restore it back to the original recorded condition.

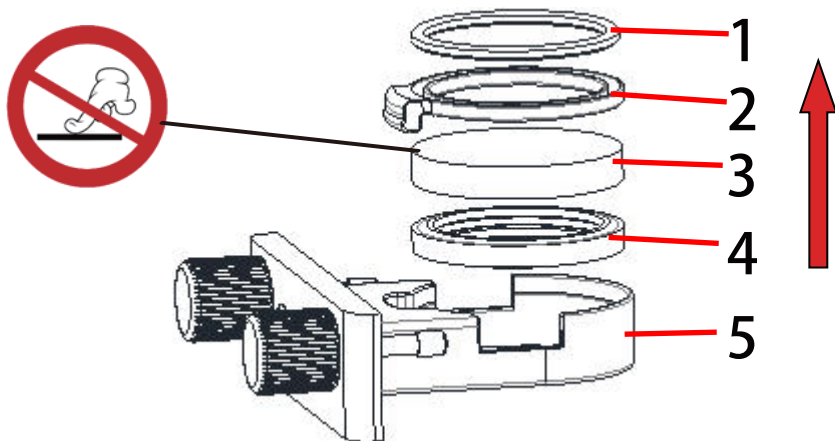

1 Sliding washer    2 Gland    3 Protection lens    4 Seal ring    5 Lens holder



Parts from 1 to 4 should be removed in the direction of the arrow, otherwise the parts will be damaged. Do not use tools such as spanners, iron pliers, etc.

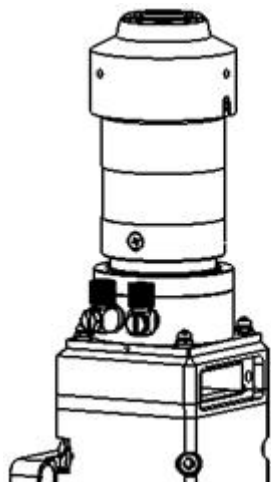

**Tip:**  
Before maintenance, please use compressed air to blow the dust on the surface of the cutting head, and then use a clean rag with alcohol to clean the corresponding parts.



power



cooling gas

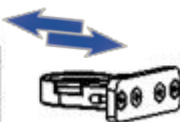

Pull out horizontally after loosening the screws

Pay attention to dust prevention: wear dustproof gloves and finger cots when removing and installing lenses, which needs to be done in a clean place. (When replacing lenses in the field, the window can be sealed with masking tape to prevent dust from entering the interior and causing contamination.)

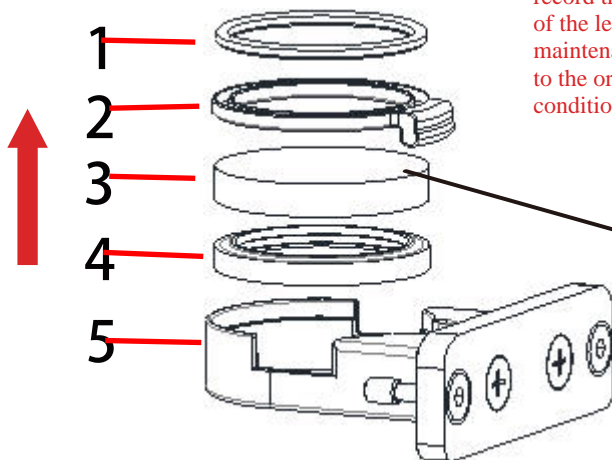

Before clean or change the lens, record the position and direction of the lens; and after the maintenance, just restore it back to the original recorded condition.



- 1 Sliding washer
- 2 Gland
- 3 Protection lens
- 4 Seal ring
- 5 Lens holder

Parts from 1 to 4 should be removed in the direction of the arrow, otherwise the parts will be damaged.



## Faults and solution

Fault	Problems	Solution
Alarm capacitor abnormal	The capacitance value is inconsistent with the system storage capacitance value	Recalibration
	The ceramic ring is loose/not in place	Reinstall the ceramic ring
	Ceramic ring is damaged	Replace with a new ceramic ring
Cooling water leaking	Water cooling connector is loose	Re-tighten the water-cooled joint nut
	The end of the water-cooled hose is uneven and not inserted to the end	Cut the hose flat and reinsert it to the end
Laser is not out	Beam falls on the inner wall of the laser head	Adjust the center of the beam
	Nozzle is blocked	Replace the nozzle
The focal length changes during cutting	Focus lock is not locked	Lock the focus lock after resetting the focus
Focusing dial can't be turned/can't be adjusted	Focus lock is not released	Unscrew the focus lock
	Damaged or dirty mechanical parts	After-sales maintenance/rework
No focus is found in the focus range	Incorrect lens configuration	Replace lenses with the right configuration
	Laser discrepancies or improper use of washers	Readjust the gasket position
	Damaged focusing lens	Replace with a new focusing lens
Poor cutting effect	Poor focus/cutting process parameters	Re-adjust focus and process parameters
	The lens is dirty or damaged	Replace dirty and damaged lenses

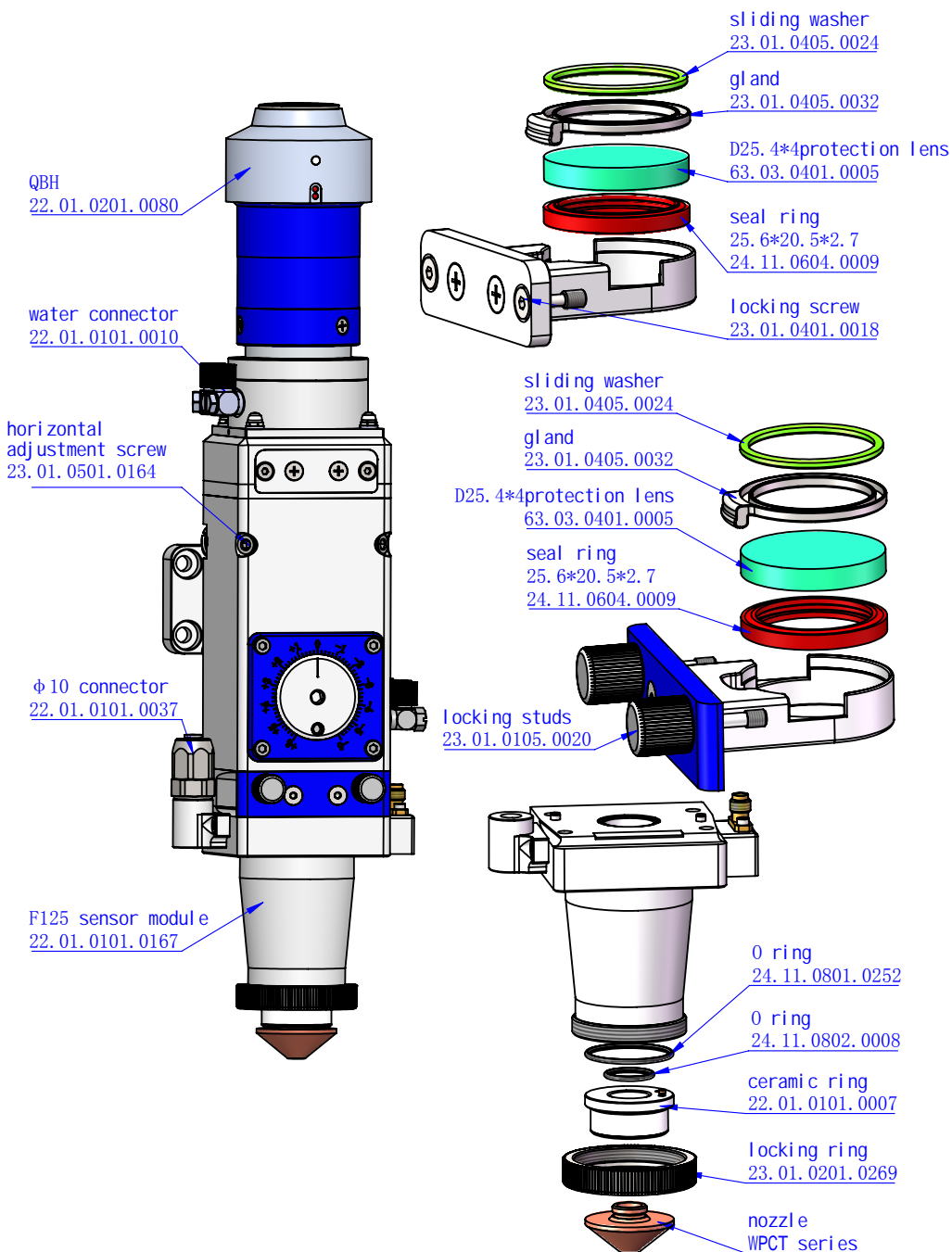



## Shenzhen Worthing Technology Co Ltd

Tel : 400-836-8816 Website : [www.wsxlaser.com](http://www.wsxlaser.com) Email : [info@wsxlaser.com](mailto:info@wsxlaser.com)

Add: Floor 3, Building 3, Langkou Industrial Zone, Dalang, Longhua District, Shenzhen, Guangdong, China  
301, Building 2, No. 432, Fengyang Road, Gun Tang Village, Yangcheng Lake Town, Xiangcheng District, Suzhou  
City, Jiangsu Province (Suzhou Branch)

401, Jiuyang Science and Technology Park, No.108 Guanggu Avenue, Hongshan District, Wuhan (Wuhan Branch)